

PRODUCT CATALOGUE

ENGLISH



Content



Dahl Engineering

About Dahl Engineering	4
Safety	5

Docking Systems

Dahl VarioDock™ and Dahl Docking Station MK II	6
Dahl VarioDock™	7
Approved installation kits for anchoring seats – Dahl VarioDock™	10
Approved installation kits ONLY for wheelchairs – Dahl VarioDock™	13
Dahl Docking Station MK II	24
Accessories	26
List of vehicles with approved installation kits - Dahl Docking Systems.....	28
Approved installation kits – Dahl Docking Station MK II	30
Tool for installing seat belt anchorage kits	40
List of tested wheelchairs and adaptation kits	41

Car Seats

Development and tests	50
COMFORT Seat	51
Approved installation kits – Dahl COMFORT Seat	52
Floor rails and reinforcements	53
Dahl HYBRID Seat	54
Accessories	57
Dahl Low Floor System	58

4-point WTORS

4-point WTORS.....	62
List of vehicles with approved installation kits – 4-point WTORS	65
Approved 4-point WTORS installation kits	68
- CLASSIC LINE	68
- EVOLUTION LINE	74
- HEAVY DUTY LINE 170kg	80
- HEAVY DUTY LINE 200kg	84
Spare parts: safety equipment for wheelchair users	88

Others

Cover for safety belt buckle.....	91
Special seat bases for original passenger seats	92
Cargo Tie-Down Equipment	93
Adapters and accessories for cargo tie-down	94
Terms of sale and delivery.....	95



Dahl Engineering was founded by Claus Dahl Pedersen, who has more than 30 years' experience in the field of development, safety testing and production of seats and safety equipment for the automobile industry.

Dahl Engineering is a specialized business enterprise that offers development, safety tests and production of various special products and equipment for vehicles for the disabled, private cars, vans, buses, racing cars, ambulances, police cars, military vehicles as well as aids and appliances for people with disabilities.

In 2005 Dahl Engineering established a 900 m² factory building, containing Denmark's only test facility for dynamic tests (crash tests), a hydraulic tensile testing facility, a prototype workshop and production facilities for research, product development and manufacturing. In 2006, 2011 and 2018 the building was extended so that there now are 2.100 square meters under its roof.

Dahl Engineering is recognized as national test laboratory by the Danish Road Safety agency (Færdselsstyrelsen). Certification tests in accordance with EU directives and international safety standards, supervised by the accredited test institute TÜV Rheinland can also be performed on the company's test facility.

New areas of focus for safety

Safety in motor vehicles is continuously developing. New issues will always continue to appear, for which new solutions and technologies will need to be found. Most wheelchairs and mobility aids for the handicapped are unable to withstand the loads they are subjected to during a road traffic accident. For wheelchair users transported by vehicle, this represents a considerable safety risk that only until recently has been the subject of only minor interest. Due to the introduction of EU-framework directive 2007/46, EU-regulation 2018/858, Annex II, Part III, Appendix 3, which addresses procedures for test and approval of restraining equipment and safety belts, new standards for the safety of wheelchair users in vehicles have been set.

In the past years there has emerged an increased focus on security when wheelchairs are used as seats in vehicles. This has i.a. led to wheelchair-tenderings requiring that the **wheelchair and restraint system is crash tested together and thus lives up to ISO 7176-19**. We receive an increasing number of enquiries about which wheelchair models are tested with our Docking system, and how the Docking system is correctly installed on the wheelchair.

We experience that car converters and occupational therapists want to assure themselves, that **they do not invalidate the CE label when mounting the Docking system**, which they do, if they do not follow the instructions of the wheelchair manufacturer.

With more than 25 years' experience in the development, safety testing and production of automotive equipment, Dahl Engineering possesses a wealth of knowledge in this area.

As a supplier of components, we are also able to offer close co-operation with regard to the development and testing/certification of components in the conjunction in which they are to be used.

Dahl Engineering is specialized in the supply of certified equipment that is tested such that international safety standards and EU safety requirements in motor vehicles are satisfied. This applies regardless of whether the products are for disabled or non-disabled use – where this is possible – with due consideration of the design and function of the aid and appliance concerned.



Dahl Docking Station

The safety standards for restraint equipment for wheelchairs are not as strict as the safety requirements for other equipment used in motor vehicles. Restraint equipment, according to the current ISO standard, only has to be able to withstand the load from a wheelchair with a weight of 85 kg.

At Dahl Engineering, we think that these requirements are inadequate, and have therefore developed the safest and most thoroughly tested system on the market. Dahl's Docking Station is supplied with the most comprehensive documentation material on the market, and is the first system to be tested and TÜV certified in a large number of vehicles for wheelchairs weighing 200 kg + user. We offer over 55 vehicle specific fitting kits.

Dahl Engineering is specialized in providing restraint equipment for wheelchair users, that meet the strict EU M1 safety requirements for cars in accordance with ECE regulations 14 and 17 (relating to the anchorage of seats and safety belts in motor vehicles) where this is possible – with due consideration of the design and function of the aid and appliance concerned.

4-point WTORS

We have performed more than 150 tests of Dahl's 4-point WTORS in vehicles according to EU-framework directive 2007/46, EU-regulation 2018/858, Annex II, Part III, Appendix 3, as well as ISO 10542-1:2012 and 7176-19:2008. Based on the number of tests, we have obtained TÜV approval for more than 85 vehicle specific fitting kits from 85 kg to 200 kg. Thus, Dahl Engineering's 4-point wheelchair restraints are at the very forefront of the latest EU safety requirements for wheelchair users in motor vehicles.

Car conversion

We offer car converters to cooperate in tests, where our products are being used, so that the converted vehicle meets applicable safety requirements. We can perform fatigue tests of the vehicle body according to TÜV Merkblatt 751. The purpose of the test is to determine if the vehicle's load carrying components will crack or collapse under the stresses it will be exposed to during years of use. The converted vehicle body can be exposed to 150.000 test cycles. Based on the tests performed, vehicle converter can then apply for acceptance of the conversion at the car manufacturer to obtain a so called "No objection certificate".



ECE regulation 17
H-point measurement



ECE regulation 14



Dahl Engineering sets again new standards for flexibility and safety!

We are happy to announce that we can now offer two different types of docking stations, which can be used for numerous different transportation needs. Besides our docking station MK II, we can now also offer an electrical height adjustable docking station, by the name of Dahl VarioDock™, which also can be used for anchoring our seats. Almost all the wheelchairs, which have been tested with our Dahl Docking Station MK II, are compatible with Dahl VarioDock™.

Please find more information about the two docking stations on the following pages.

Our new Dahl VarioDock™ is not only the only power-height adjustable wheelchair Docking station, which facilitates securing wheelchairs with different ground clearances and vehicle passenger seats with integrated 3 point belt, but it is also the only system to meet standard ISO 10542-1, ISO 7176-19 and the strict M1 in-vehicle testing requirements for seats and seat belt anchorages according to ECE regulations 14 and 17.

Thanks to the Dahl VarioDock™ system, securing wheelchair users and other seated occupants can be carried out with an unprecedented ease, speed and safety. The Dahl VarioDock™ docking system offers more flexibility and versatility than any other seat anchoring system because the seat and wheelchair layout can be changed very quickly with a minimum of effort and time consumption. A docking system also improves the working environment considerably for drivers, who often struggle with cramped spaces and bad working positions when tying down wheelchairs with 4 point strap systems.

- Power height adjustment from 61 - 91 mm.
- Time consumption only ¼ of tying down wheelchair with 4 point strap system.
- Tested for wheelchairs with a weight of up to 200 kg plus user.
- Approved for anchoring Dahl COMFORT Seat
- 4 step power tightening system to eliminate unwanted play.
- Opening time for lock selectable in 5 or 8 seconds intervals.
- "Maintenance required" warning in display
- Improves working environment for drivers.
- No tie down straps on vehicle floor to trip over.
- Crash tested and CE-marked with approximately 100 wheelchairs



Dahl VarioDock™

Our electrically height-adjustable Docking Station, enables fastening of wheelchairs with different ground clearances and seats with an integrated 3-point belt.

- Complies with ISO 10542-1, ISO 7176-19 and the strict test requirements in accordance with ECE Regulations 14 and 17 regarding test of seats and belt anchorages in vehicle category M1.
- Electrical height adjustment (from 61-91 mm).
- Tested for wheelchairs weighing up to 200 kg plus user.
- Approved for anchoring Dahl COMFORT Seat
- Crash tested and CE marked with approx. 100 wheelchairs.

Dahl VarioDock™



Patent pending



Dahl Docking Station MK II

is our second generation Docking Station, which enables the tiedown of wheelchairs from many different wheelchair manufacturers.

- Complies with ISO 10542-1, ISO 7176-19 and the strict test requirements according to ECE regulations 14 and 17 regarding testing of seats and seat belt anchorages in vehicle category M1.
- Height adjustment through use of spacers
- Tested for wheelchairs weighing up to 200 kg plus user
- Crash tested and CE marked with approx. 100 wheelchairs.





Dahl VarioDock™ can be used to secure manual and powered wheelchairs with a weight of up to 200 kg plus user, as well as our Dahl COMFORT Seat with integrated 3 point safety belt.



Contents of Dahl VarioDock™ base kit #503600.



Anchorage of Dahl COMFORT Seat with integrated 3-point seat belt

Dahl VarioDock™ has also been tested and approved for anchoring Dahl COMFORT Seat with integrated 3-point seat belt, placed on seat row 2 or behind, in a number of vehicle models.

Using VarioDock™ for anchoring the Dahl COMFORT Seat with an integrated 3-point seat belt requires a particularly strong reinforcement kit for the vehicle floor which is designed, tested and approved for the specific vehicle and installation position.

In the event of a collision, the vehicle's floor will be subjected to a much higher torque / load when using a seat with integrated seat anchorage points, than when using a wheelchair, where all seat anchorage points are rooted in the vehicle body and floor.

Please see the current delivery programme of approved and vehicle-specific anchoring kits in our product catalogue, which can be downloaded from our website <http://wtors.com>

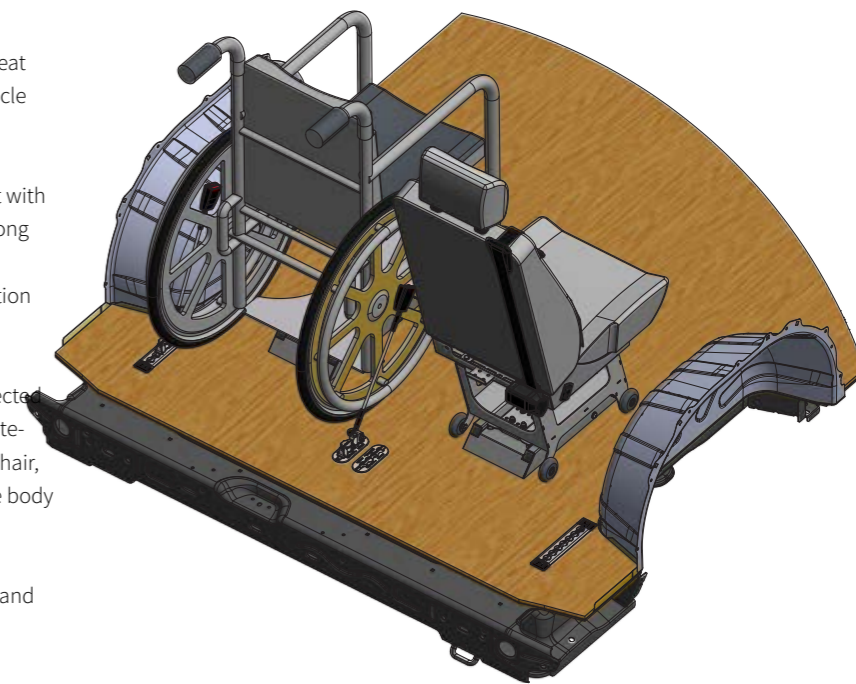

WARNING! Risk of death or serious injury

Do not use VarioDock™ to anchor Dahl COMFORT Seats or other seats with integrated seat belt anchor points, if the vehicle has not been fitted with an approved reinforcement kit for VarioDock™.

If a reinforcement kit that has been approved for this use has not been fitted, there is a risk that the user and other passengers in the vehicle may suffer serious or fatal injuries during a collision as a result of the vehicle floor being deformed severely or the anchoring points of the docking station being torn loose.

Therefore, ask your dealer if a VarioDock™ reinforcement kit approved for anchorage of Dahl COMFORT Seat has been fitted to the vehicle and mounting position prior to commissioning.

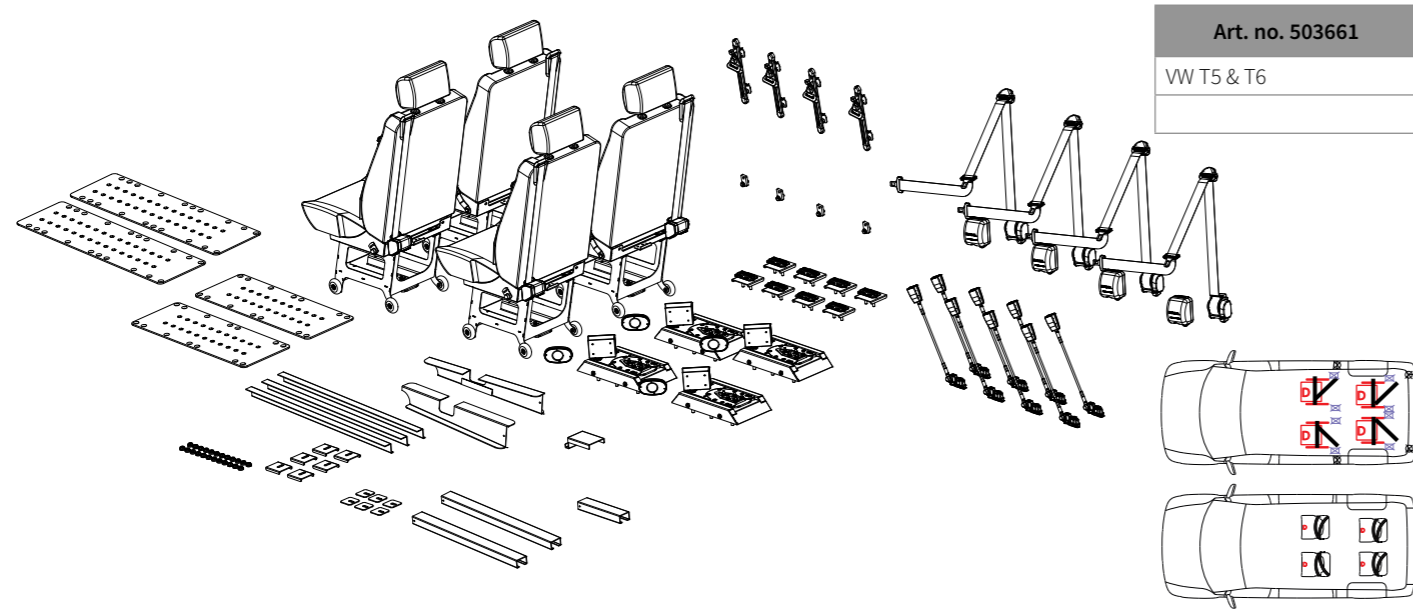

Art. no. 503661
VW T5 & T6

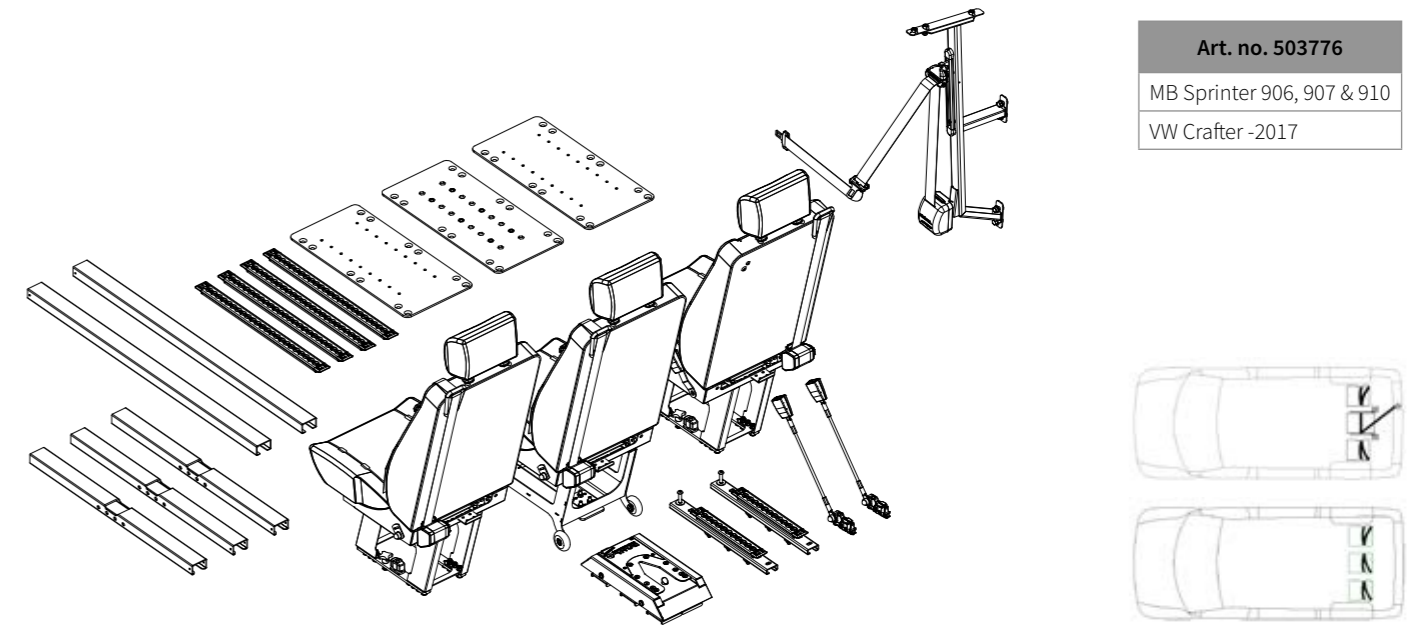

Art. no. 503776
MB Sprinter 906, 907 & 910
VW Crafter -2017

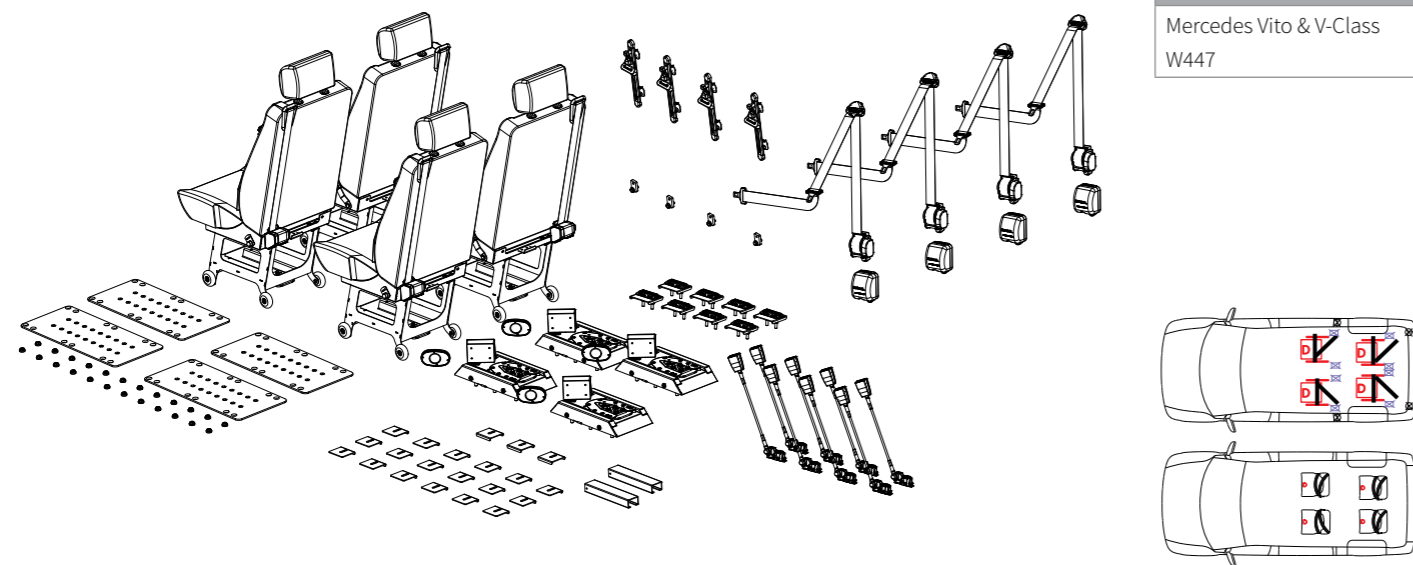

Art. no. 503662
Mercedes Vito & V-Class
W447

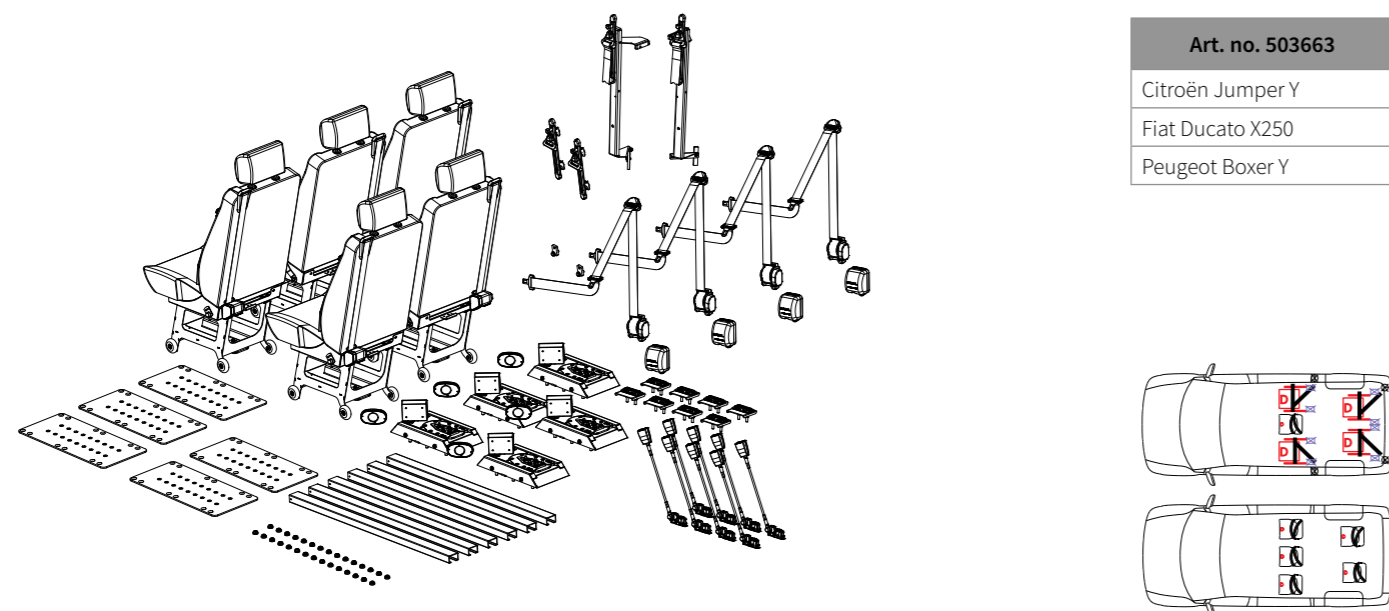

Art. no. 503663
Citroën Jumper Y
Fiat Ducato X250
Peugeot Boxer Y

Be sure to check national regulations with regard to minimum clear space requirements and access to emergency exists for seats and wheelchairs for the vehicle concerned.



Art. no. 503902
 MB Sprinter 906 & 907
 VW Crafter (2006-2016)

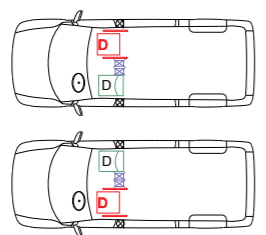

Art. no. 503903
 MB Sprinter 906 & 907
 VW Crafter (2006-2016)

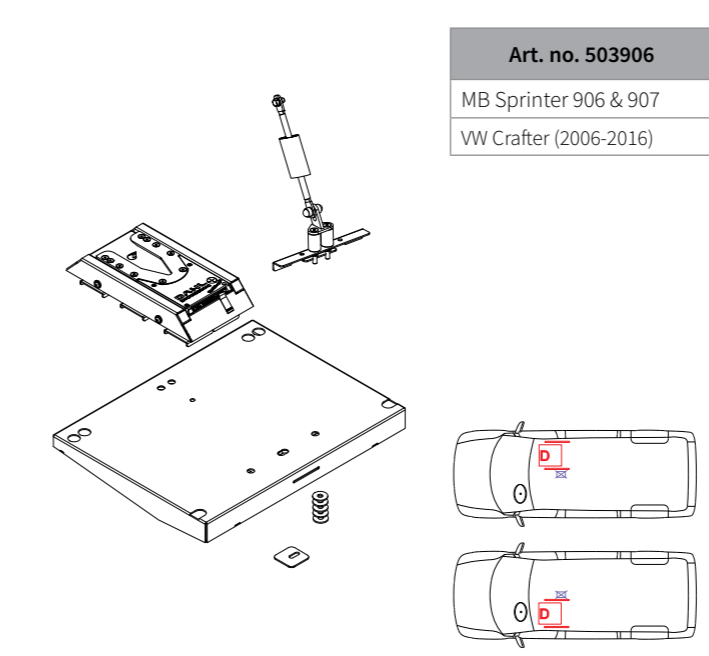
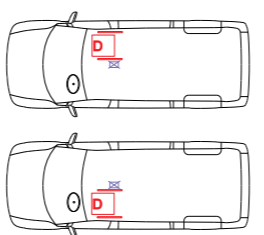

Art. no. 503906
 MB Sprinter 906 & 907
 VW Crafter (2006-2016)

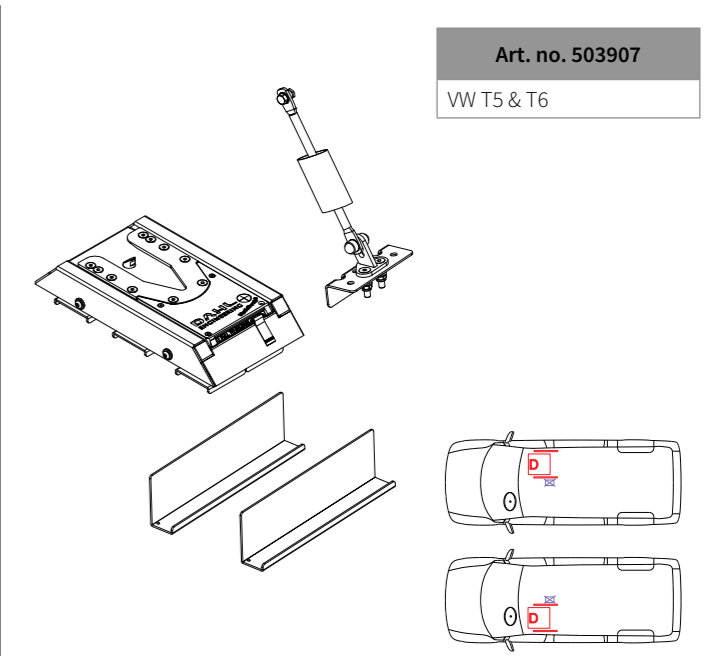
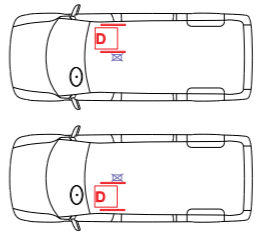

Art. no. 503907
 VW T5 & T6

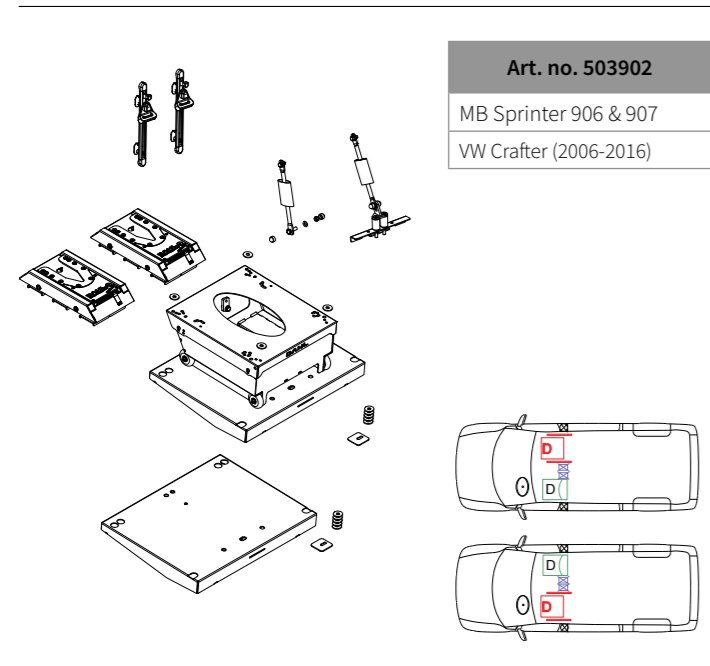
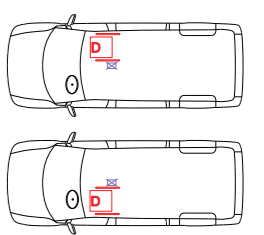

Art. no. 503904
 VW T5 & T6

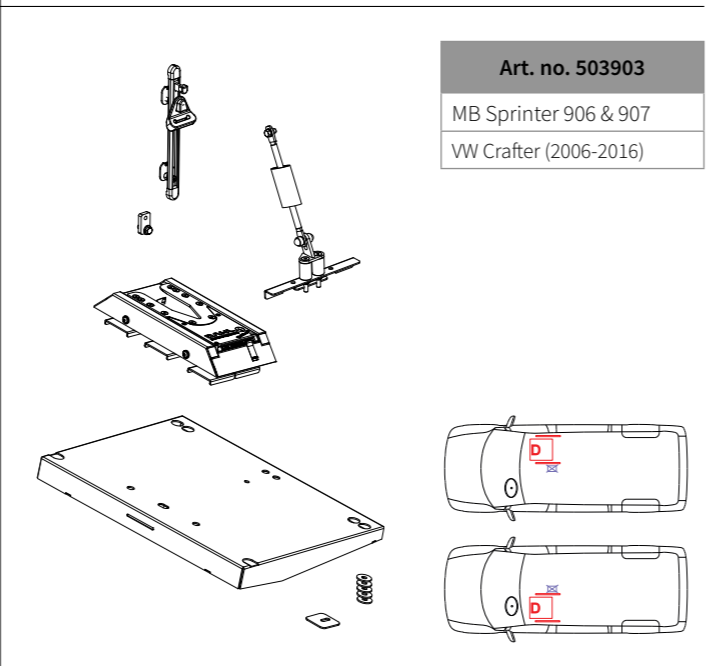
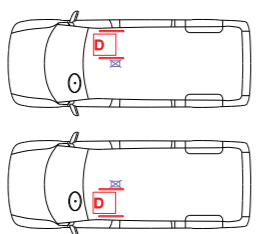

Art. no. 503905
 MB Sprinter 906 & 907
 VW Crafter (2006-2016)

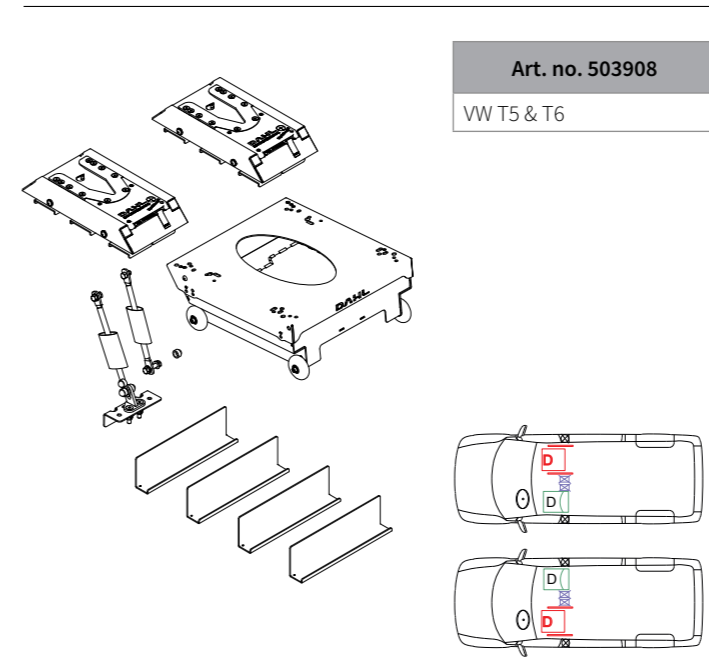
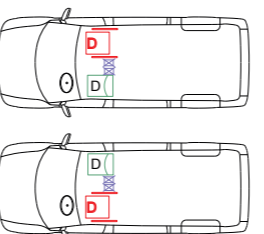

Art. no. 503908
 VW T5 & T6

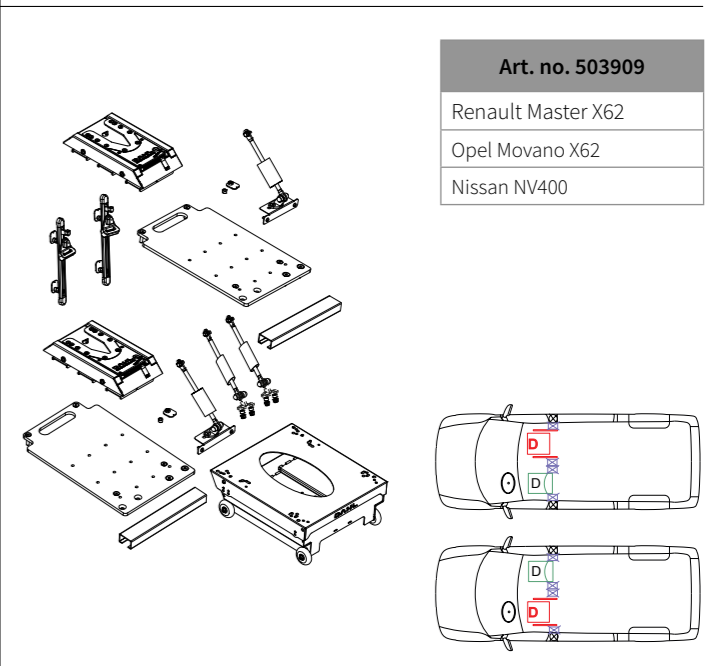
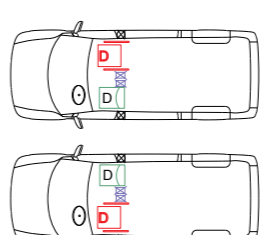

Art. no. 503909
 Renault Master X62
 Opel Movano X62
 Nissan NV400

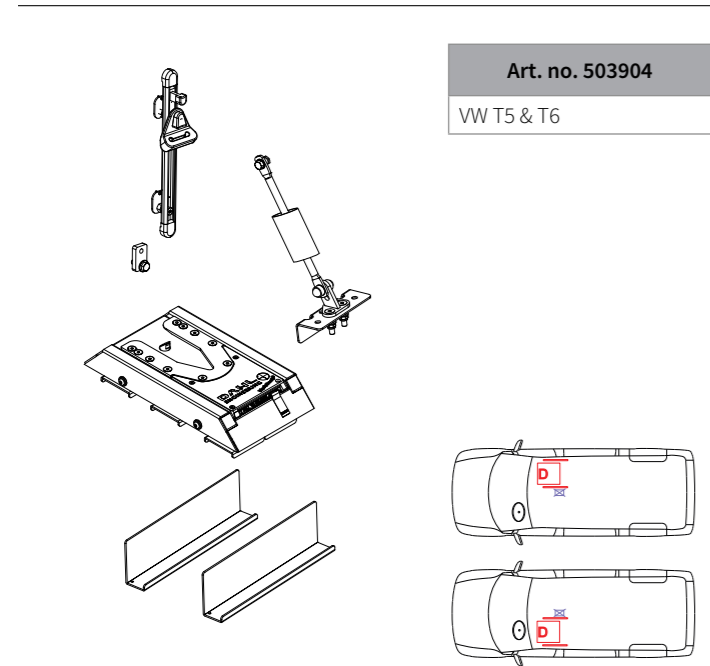
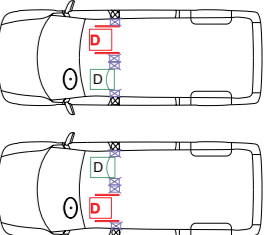

Art. no. 503904
 VW T5 & T6

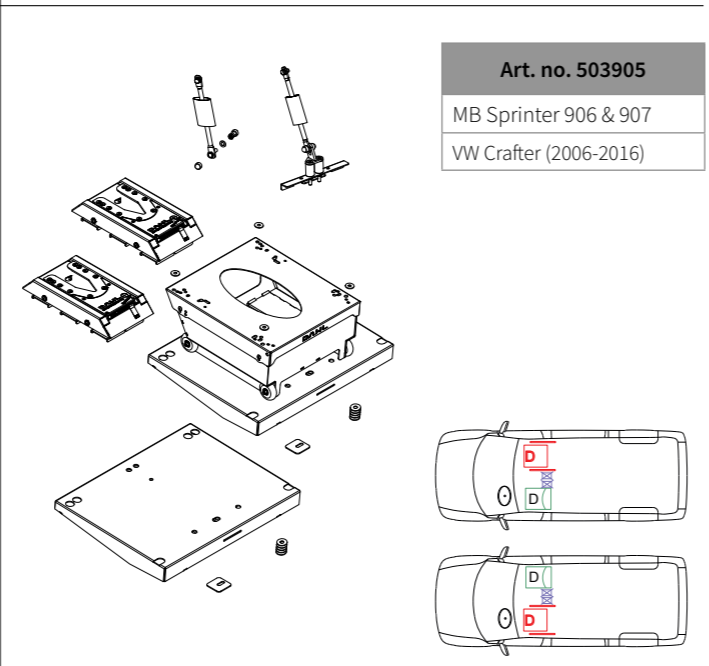
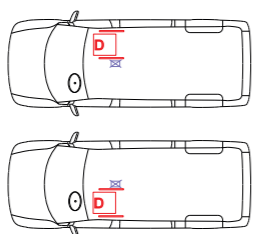

Art. no. 503905
 MB Sprinter 906 & 907
 VW Crafter (2006-2016)

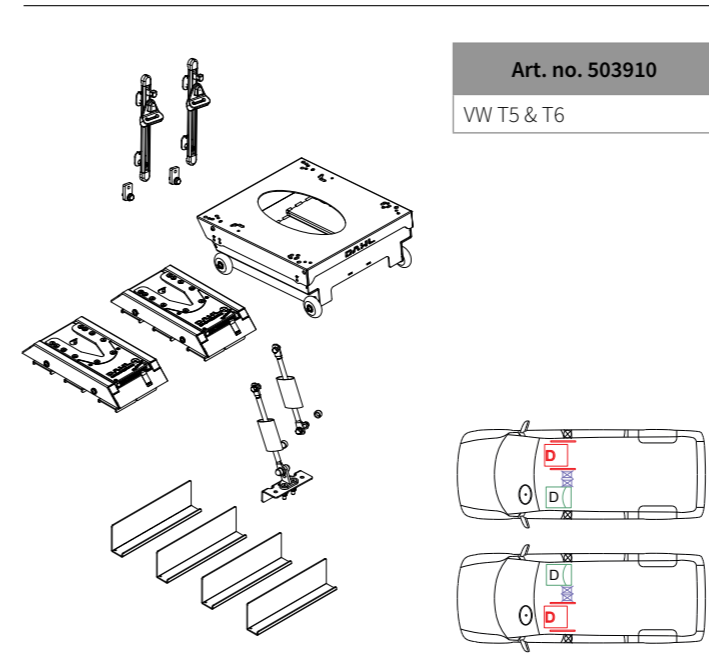
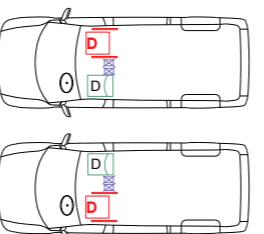

Art. no. 503910
 VW T5 & T6

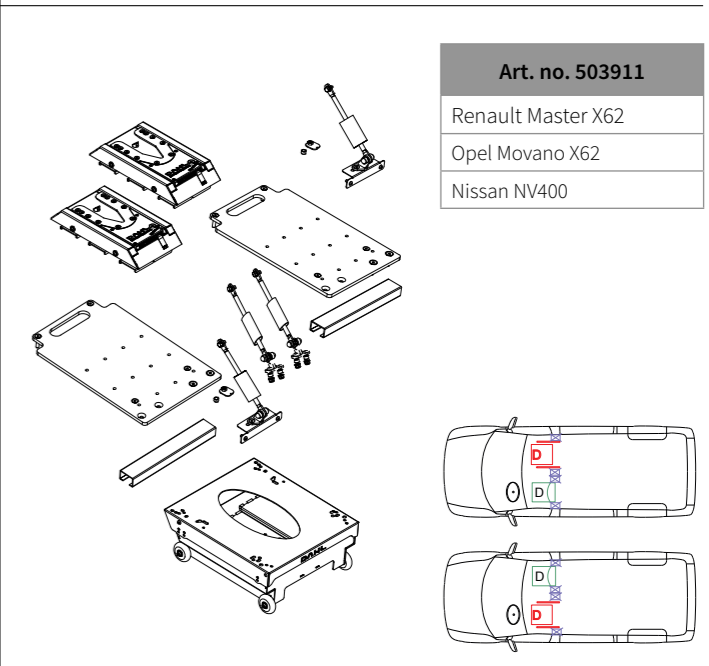
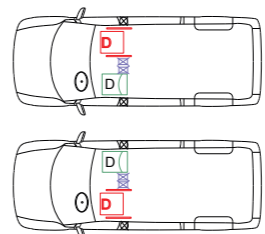

Art. no. 503911
 Renault Master X62
 Opel Movano X62
 Nissan NV400

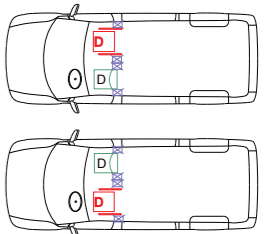

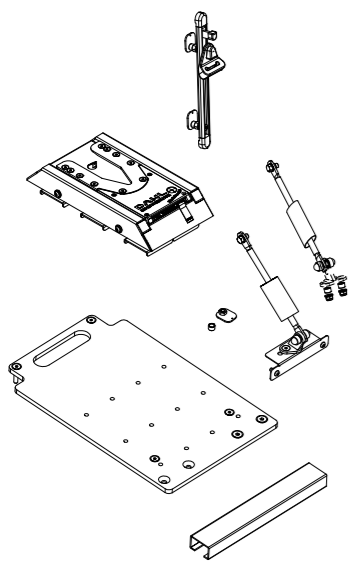

Art. no. 503912
Renault Master X62
Opel Movano X62
Nissan NV400

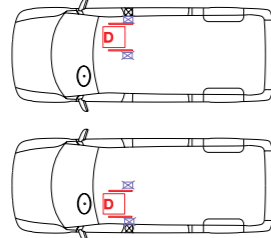
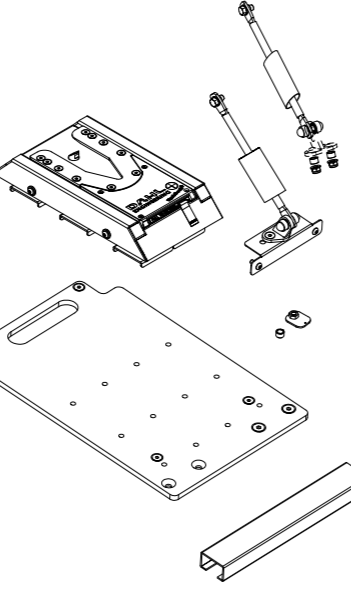
Art. no. 503913
Renault Master X62
Opel Movano X62
Nissan NV400

Art. no. 503918
MB Vito & V-Class W447

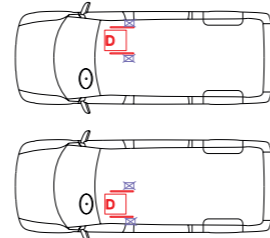
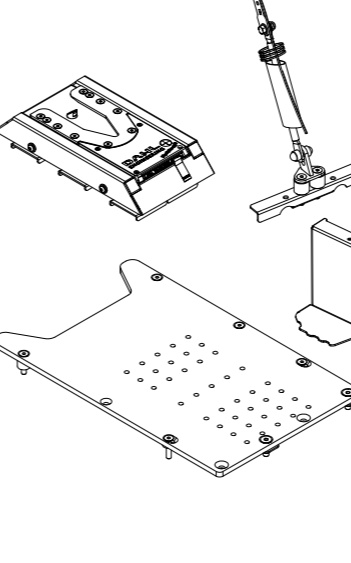
Art. no. 503919
MB Vito & V-Class W447

Art. no. 503914
MB Vito & V-Class W447

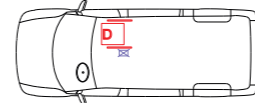
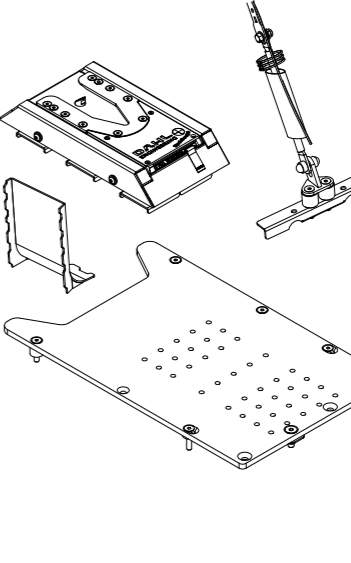

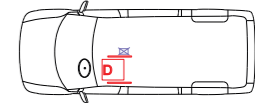
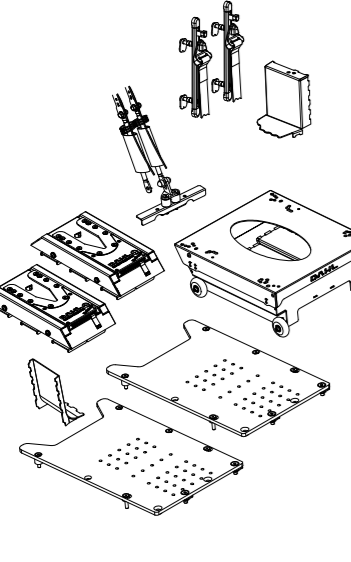

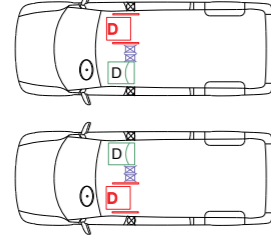
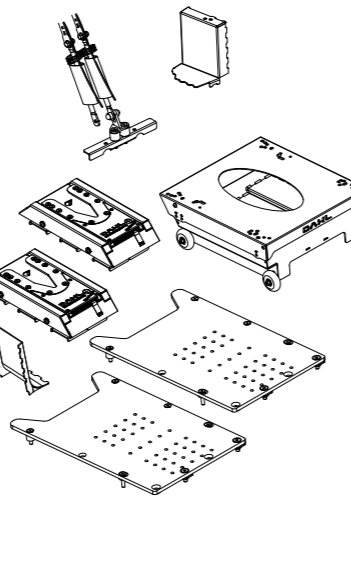
Art. no. 503915
MB Vito & V-Class W447

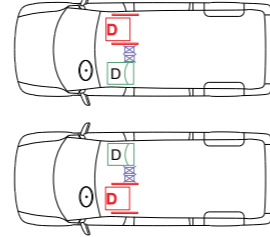

Art. no. 503920

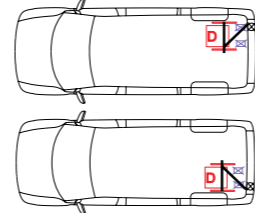
- Fiat Talento 2016-
- Man TGE 2017-
- MB Sprinter 906 & 907 & 910
- Mitsubishi Express X82 (AU & NZ)
- Nissan Primastar
- Nissan NV 300
- Opel Vivaro X83 & X82
- Renault Traffic X83 & X82
- VW Crafter -2016
- VW Crafter 2017-



Art. no. 503920

- Citroën Jumper Y
- Citroën Jumpy X
- Fiat Ducato X250
- Fiat Scudo X270
- Fiat Talento
- Ford Transit Custom V362
- MB Vito W639 & W447
- Nissan NV300
- Nissan Primastar
- Opel Vivaro X83 & X82
- Peugeot Boxer Y
- Peugeot Expert X
- Renault Trafic X83 & X82
- Toyota Proace
- VW T5 & T6



Art. no. 503921

- Fiat Talento 2016-
- Man TGE 2017-
- MB Sprinter 906 & 907 & 910
- Mitsubishi Express X82 (AU & NZ)
- Nissan Primastar
- Nissan NV 300
- Opel Vivaro X83 & X82
- Renault Traffic X83 & X82
- VW Crafter -2016
- VW Crafter 2017-

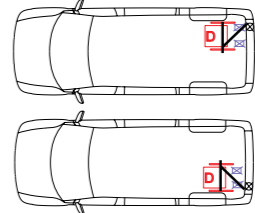

Art. no. 503921

- Citroën Jumper Y
- Citroën Jumpy X
- Fiat Ducato X250
- Fiat Scudo X270
- Fiat Talento
- Ford Transit Custom V362
- MB Vito W639 & W447
- Nissan NV300
- Nissan Primastar
- Opel Vivaro X83 & X82
- Peugeot Boxer Y
- Peugeot Expert X
- Renault Trafic X83 & X82
- Toyota Proace
- VW T5 & T6

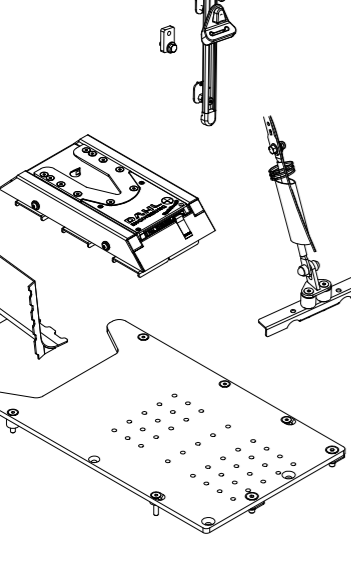
Art. no. 503916
MB Vito & V-Class W447

Art. no. 503917
MB Vito & V-Class W447

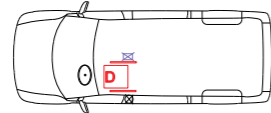
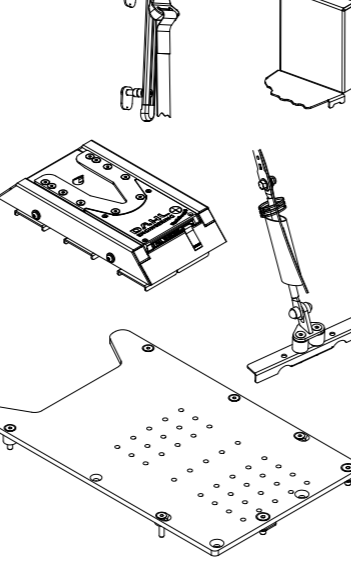

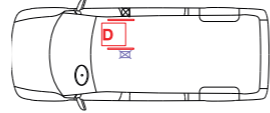
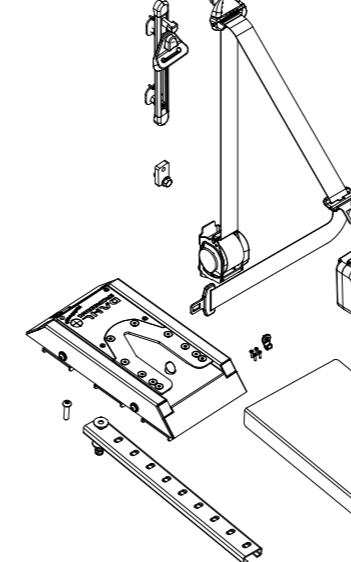

Art. no. 503920

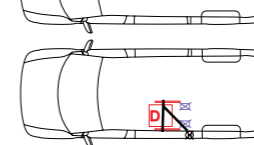
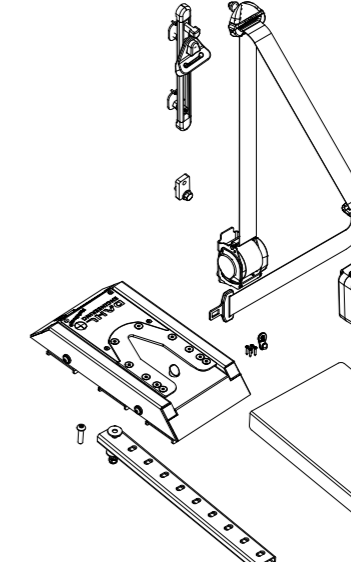

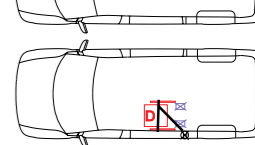

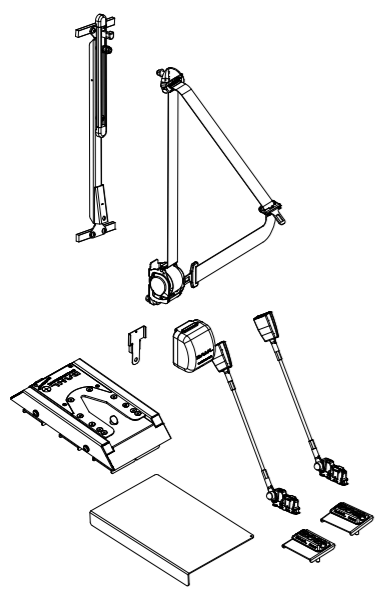
Art. no. 503921



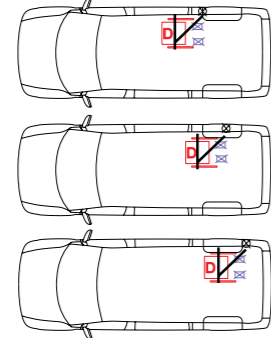
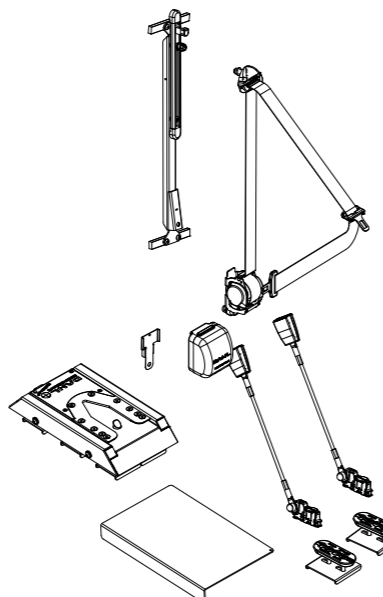

Art. no. 503922
VW T5 & T6

Art. no. 503923
VW T5 & T6

Art. no. 503928
Citroën Jumper Y
Fiat Ducato X250
Peugeot Boxer Y

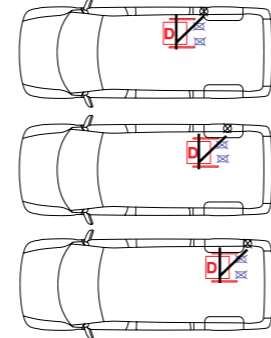
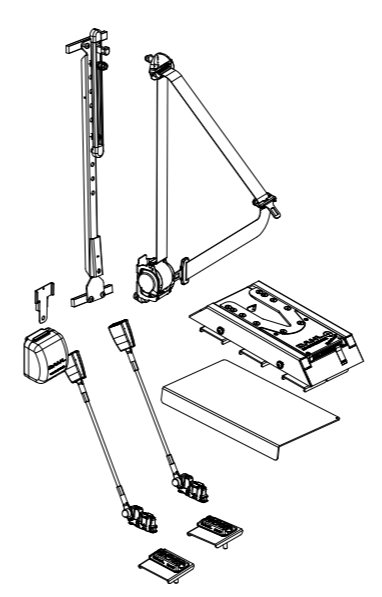
Art. no. 503929
Citroën Jumper Y
Fiat Ducato X250
Peugeot Boxer Y

Art. no. 503924
MB Sprinter 906 & 907 & 910
VW Crafter (2006-2016)

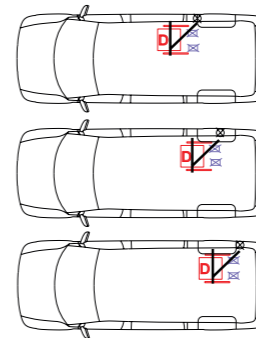
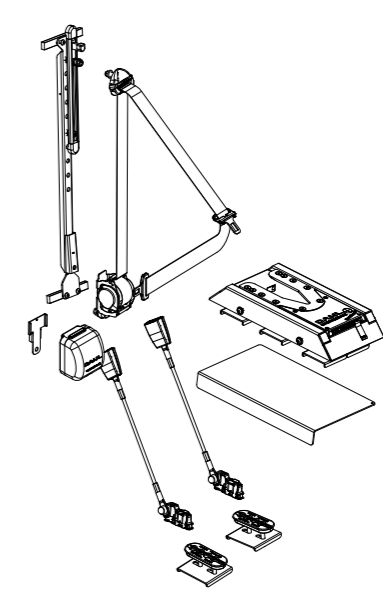
Art. no. 503925
MB Sprinter 906 & 907 & 910
VW Crafter (2006-2016)

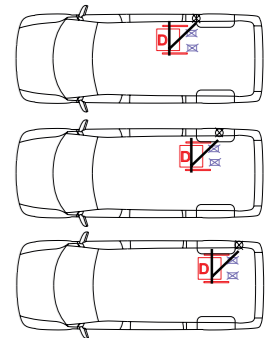
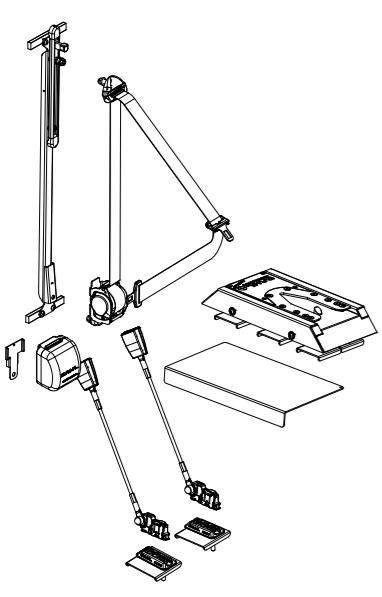
Art. no. 503930
Nissan NV 400
Opel Movano X62
Renault Master X62

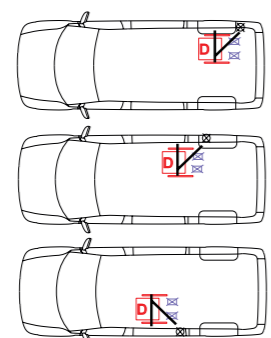
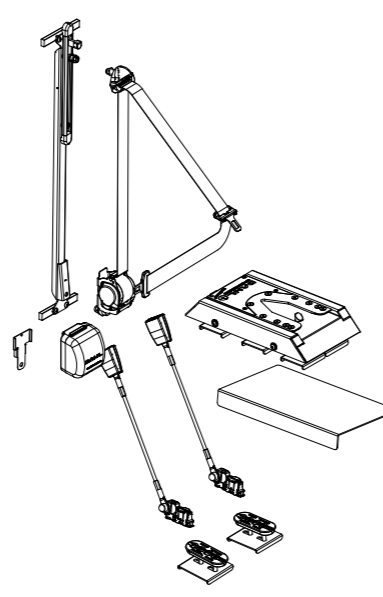
Art. no. 503931
Nissan NV 400
Opel Movano X62
Renault Master X62

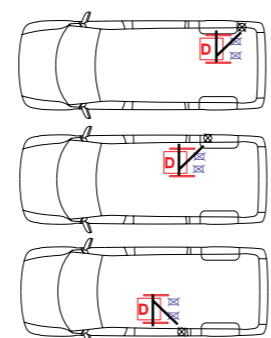
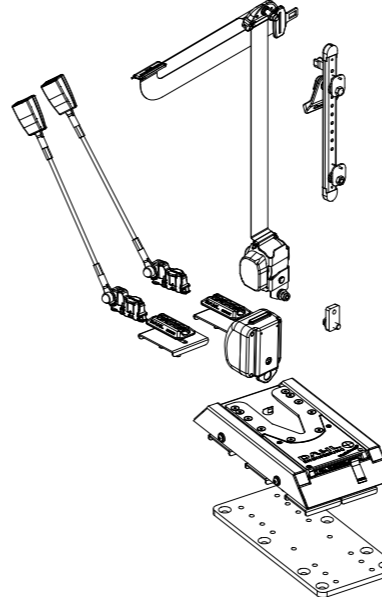
Art. no. 503926
Citroën Jumpy X
Fiat Scudo X270
Ford Transit Custom V362
MB Vito & V-Class W447
Peugeot Expert X
Toyota ProAce
VW T5 & T6

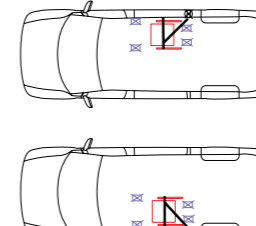
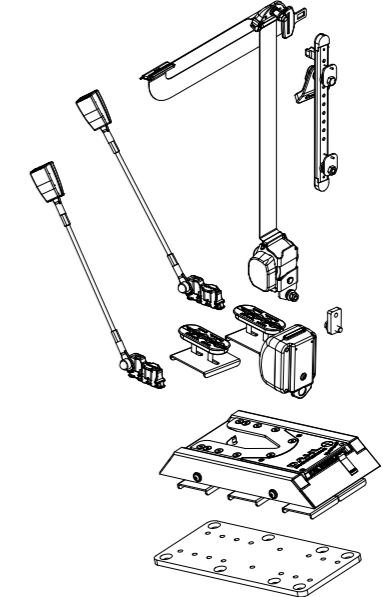
Art. no. 503927
Citroën Jumpy X
Fiat Scudo X270
Ford Transit Custom V362
MB Vito & V-Class W447
Peugeot Expert X
Toyota ProAce
VW T5 & T6

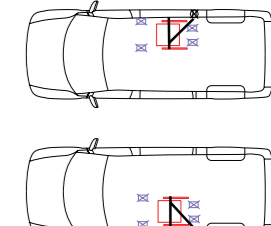
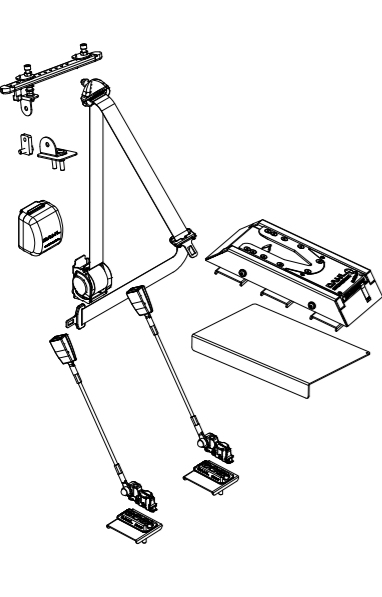

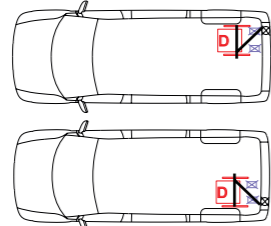
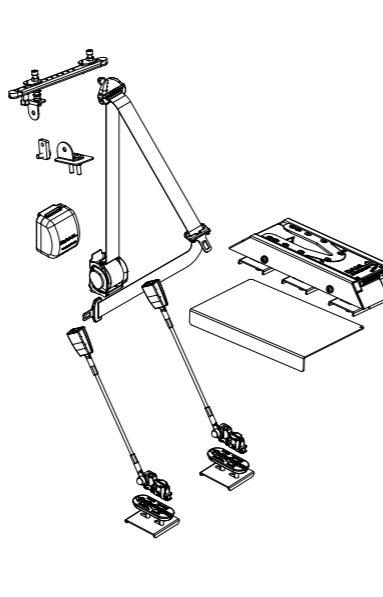

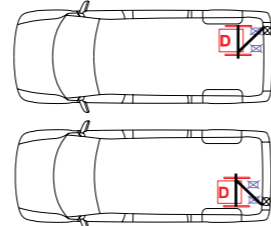
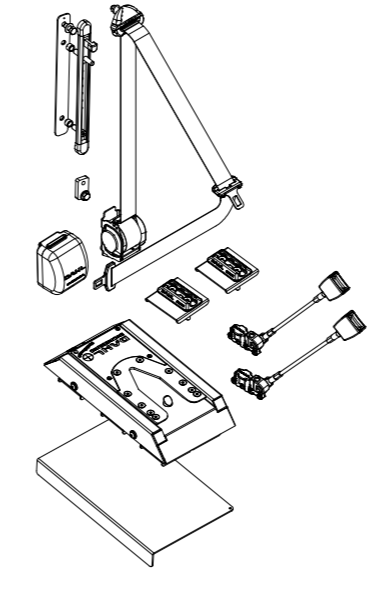
Art. no. 503932
Ford Transit V363

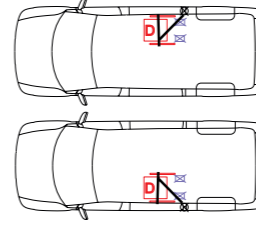
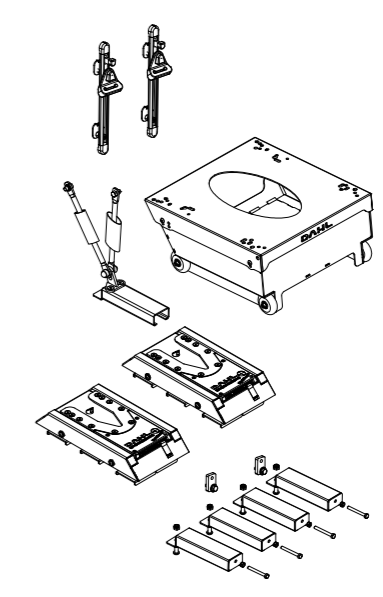

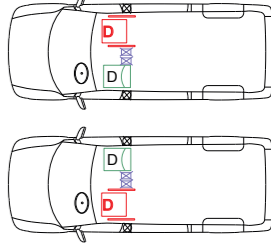

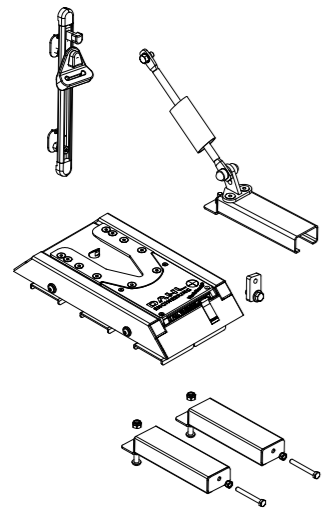
Art. no. 503933
GM Coachwork Drop floor conversion:
VW Caravelle SE Colorado



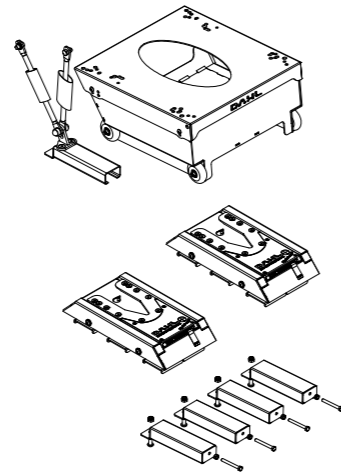
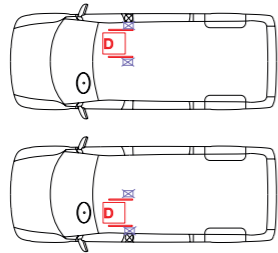

Art. no. 502286
GM Coachwork
Drop floor conversion:
VW Caravelle SE Colorado



Art. no. 502287
GM Coachwork
Drop floor conversion:
VW Caravelle SE Colorado

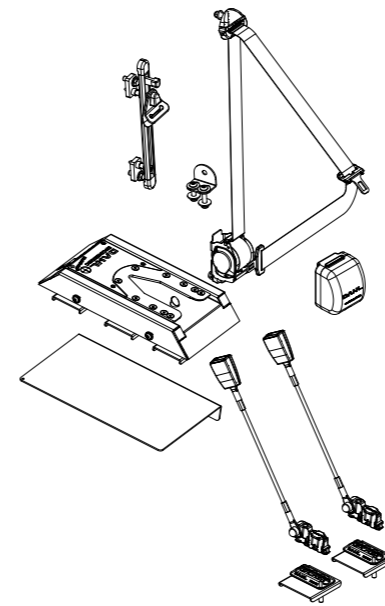
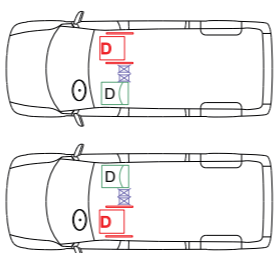

Art. no. 503121
Fiat Doblo
High roof SWB & LWB
Opel Combo
High roof SWB & LWB

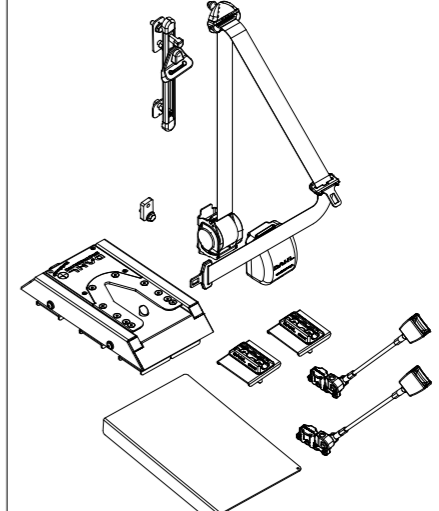
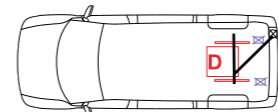

Art. no. 503142
VW Crafter 2017-
MAN TGE 2017-

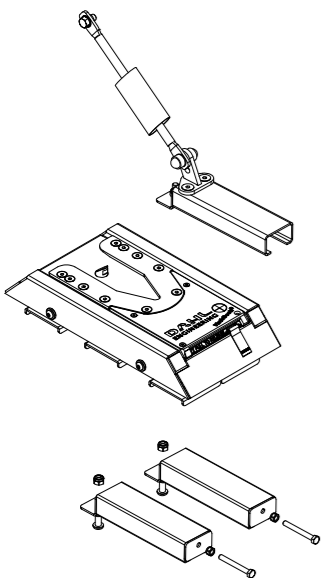
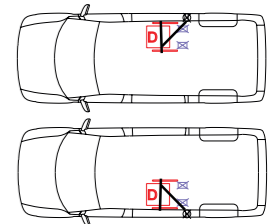

Art. no. 502288
GM Coachwork
Drop floor conversion:
VW Caravelle SE Colorado

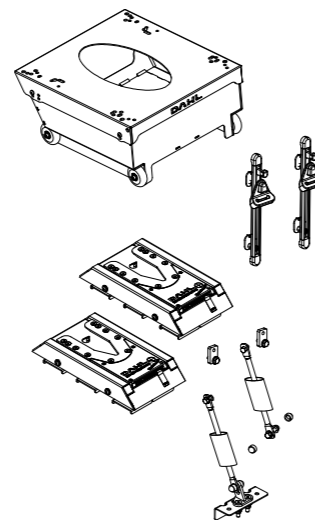
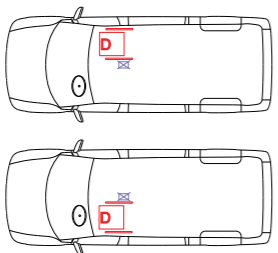

Art. no. 502368
Zawatzky Drop Floor
Conversion:
VW T6 Centervan

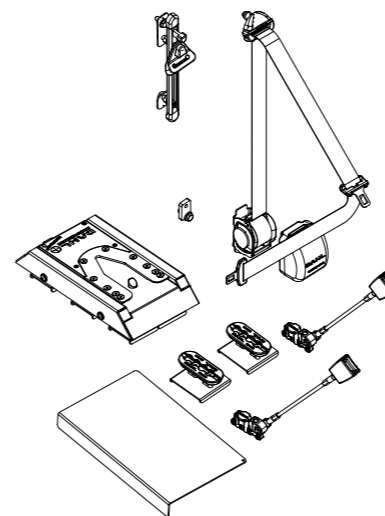
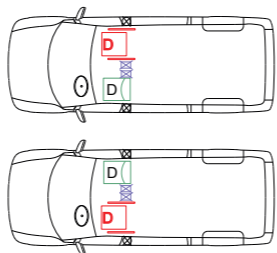

Art. no. 503143
VW Crafter 2017-
MAN TGE 2017-

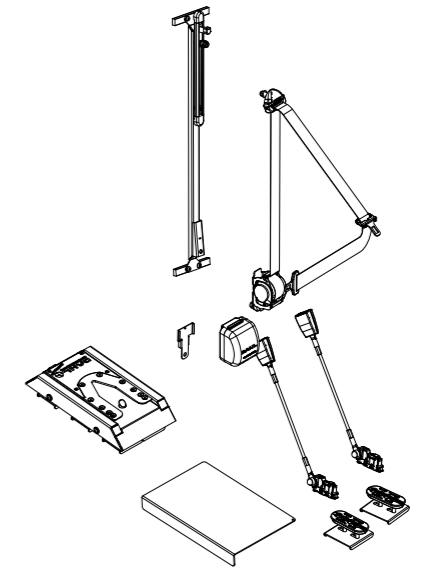
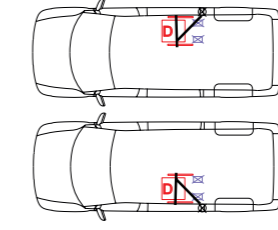

Art. no. 503144
VW Crafter 2017-
MAN TGE 2017-

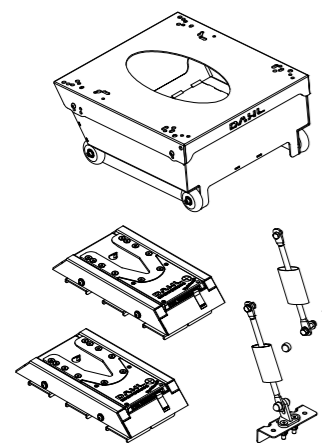
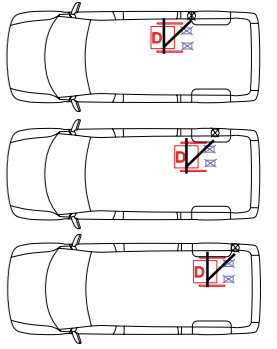

Art. no. 502369
Zawatzky Drop Floor
Conversion:
VW T6 Centervan

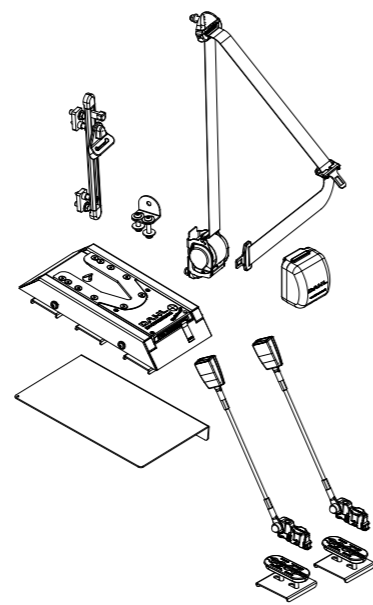
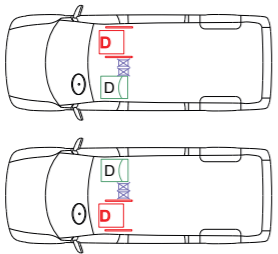

Art. no. 503120
Fiat Doblo
High roof SWB & LWB
Opel Combo
High roof SWB & LWB

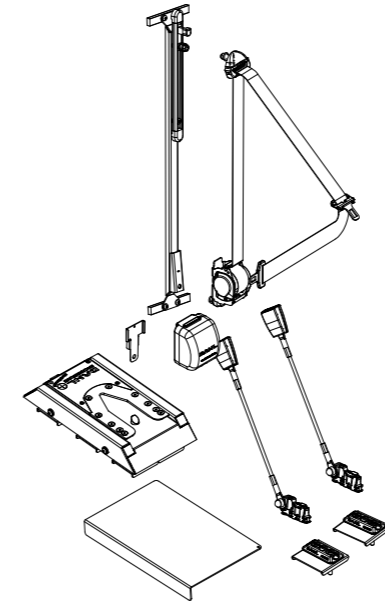
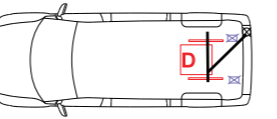

Art. no. 503145
VW Crafter 2017-
MAN TGE 2017-

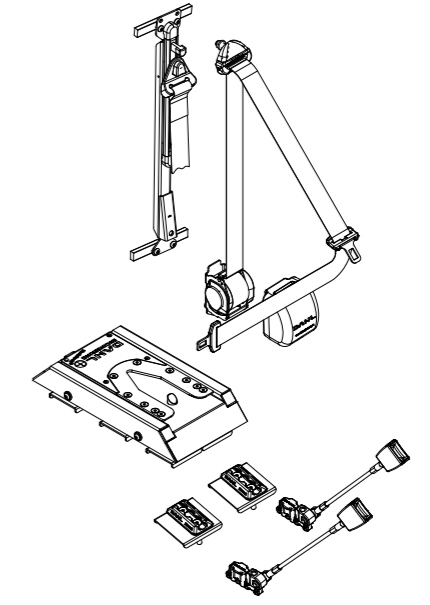
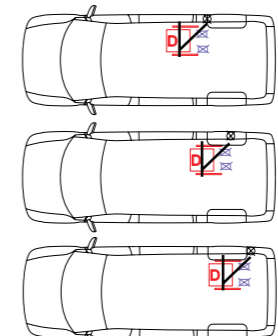

Art. no. 503197
Nissan NV 200

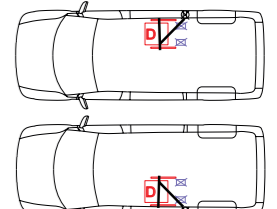

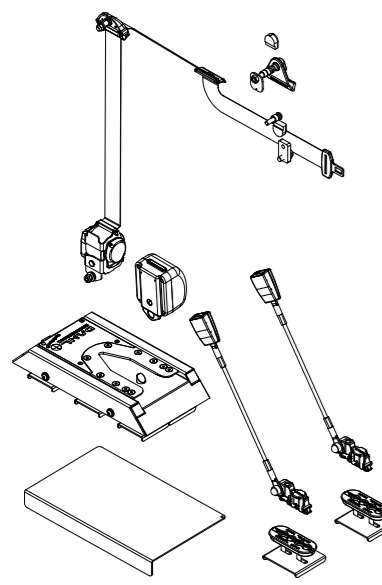

Art. no. 503301
Citroën Jumpy & Spacetourer KO
Opel Zafira Life
Peugeot Expert & Traveller KO
Toyota Proace & Proace Verso 2016-

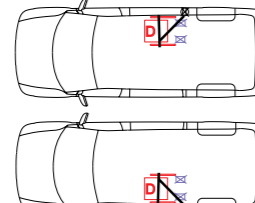
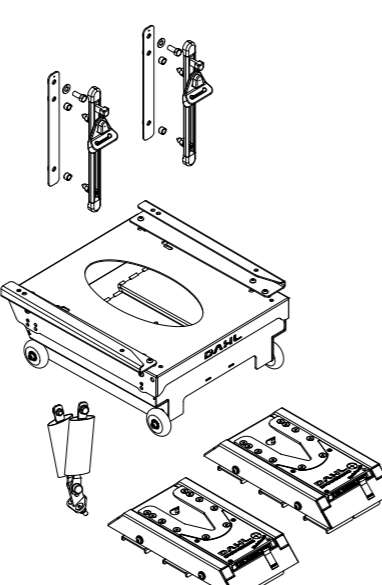
Art. no. 503255
ITEK Drop Floor Conversion:
VW Caddy Active

Art. no. 503310
ITEK Drop Floor Conversion:
VW Caddy Active

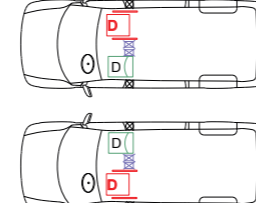
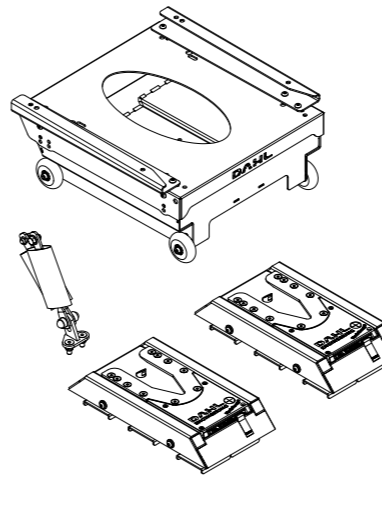
Art. no. 503302
Citroën Jumpy & Spacetourer KO
Opel Zafira Life
Peugeot Expert & Traveller KO
Toyota Proace & Proace Verso 2016-

Art. no. 503303
Citroën Jumpy & Spacetourer KO
Opel Zafira Life
Peugeot Expert & Traveller KO
Toyota Proace & Proace Verso 2016-

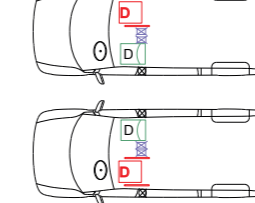
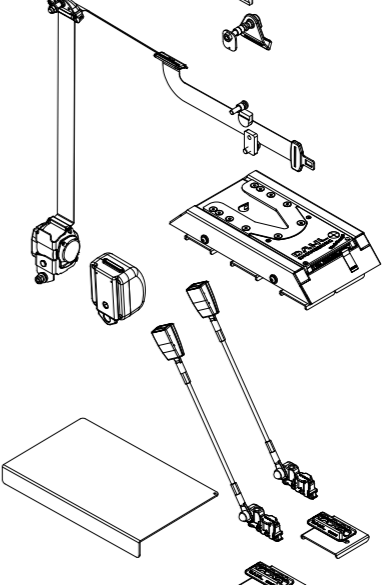
Art. no. 503304
Citroën Jumpy & Spacetourer KO
Opel Zafira Life
Peugeot Expert & Traveller KO
Toyota Proace & Proace Verso 2017-

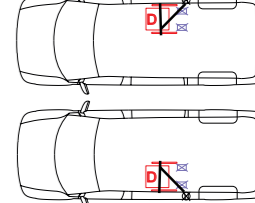
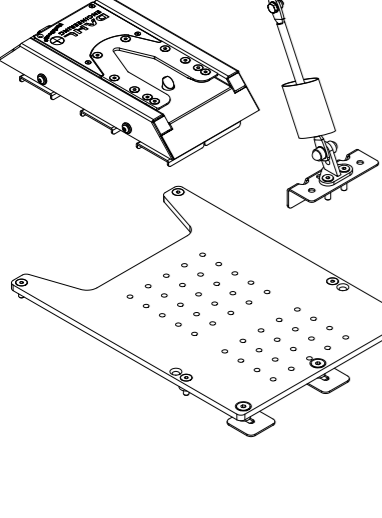
Art. no. 503461
Tripod/Allied Drop Floor Conversion:
Citroën Berlingo
Peugeot Partner

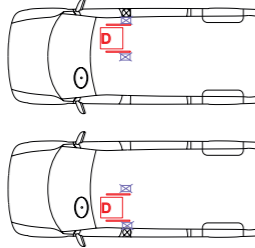
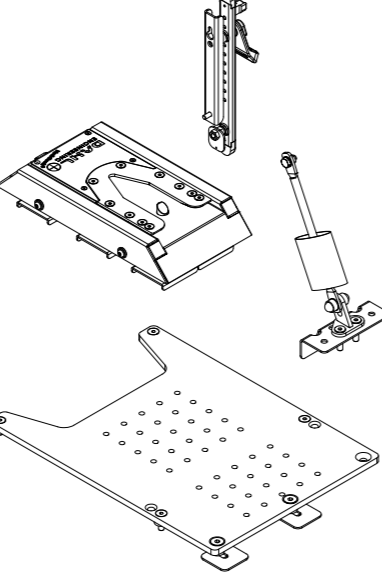

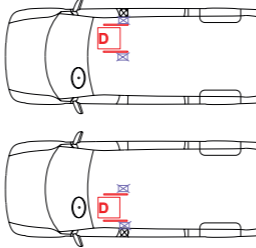
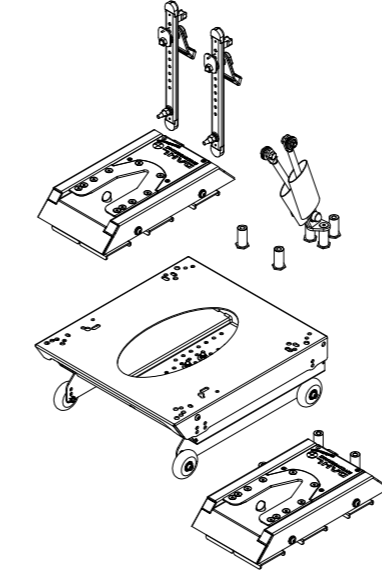

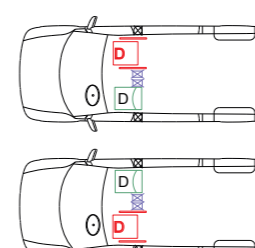
Art. no. 503302
Citroën Jumpy & Spacetourer KO
Opel Zafira Life
Peugeot Expert & Traveller KO
Toyota Proace & Proace Verso 2016-

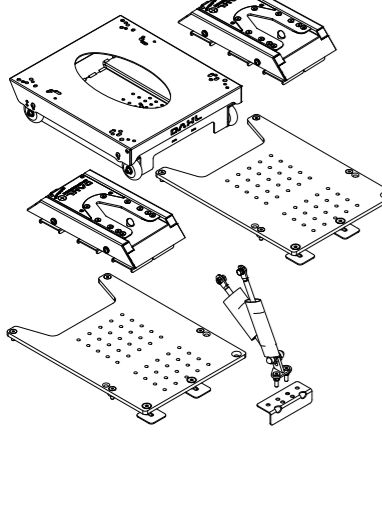

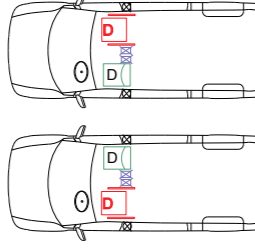
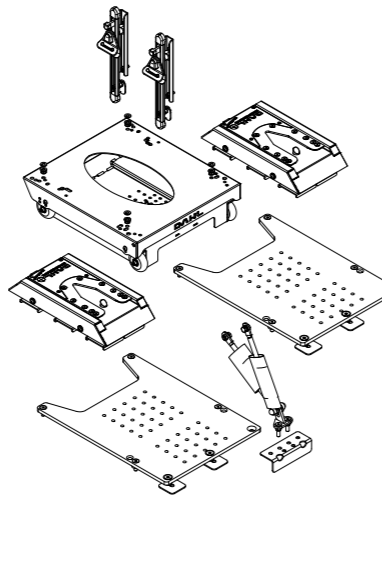

Art. no. 503305
Citroën Jumpy & Spacetourer KO
Opel Zafira Life
Peugeot Expert & Traveller KO
Toyota Proace & Proace Verso 2016-

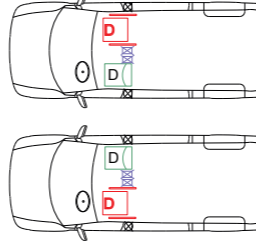
Art. no. 503306
Citroën Jumpy & Spacetourer KO
Opel Zafira Life
Peugeot Expert & Traveller KO
Toyota Proace & Proace Verso 2016-



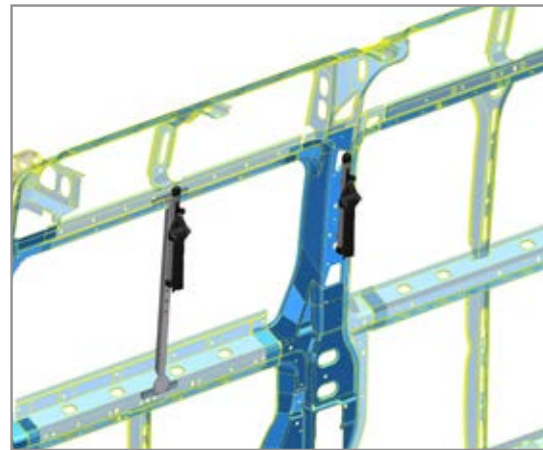

Tool for installing seat belt anchorage kits

When installing a special seat, or adapting a vehicle to accommodate a wheelchair user, it is often very difficult or impossible to mount the seat belts to tested and approved anchorage points, when the vehicle's original seat has been removed.

The reason is that original seats of today are often equipped with integrated seat belts, and once the original seats have been taken out of the vehicle, one or all of the tested seat belt anchorage points have disappeared with the removed seats.

Therefore we have developed and tested retrofitable seat belt anchorage kits consisting of a height adjuster for the shoulder belt and vehicle specific reinforcing brackets that can be placed inside the vehicles side and under the floor.

These kits can for example be used to anchor the buckle for the vehicles original safety belt or in conjunction with one of our certified 3 point occupant restraints for wheelchair users.



Special tool for installation, with 7/16" UNF thread



Special tool for installation, M8 thread

Examples of tested vehicle models with our Dahl Docking Systems



Mercedes Sprinter, VW Crafter



Ford Transit Custom



Mercedes Vito/Viano



VW T5



Opel Vivaro / Renault Trafic



Ford Transit



Nissan NV400, Opel Movano, Renault Master



VW Caddy



Peugeot Partner / Citroën Berlingo



Fiat Ducato / Peugeot Boxer / Citroën Jumper



Citroën Jumpy / Peugeot Expert / Fiat Scudo

EU legislation when installing a docking system to a wheelchair

The EU medical device directive states that a CE-marked medical device, which has been customized outside the manufacturer's specifications, thereby become a customized medical device and that the CE-marking must be removed. Anyone who customizes a CE-marked medical device outside the manufacturers specifications is responsible for quality, safety and performance of the device and becomes the responsible manufacturer of the customized device.

Complying with the wheelchair manufacturers user- and installation guide when installing the Dahl Docking System, will ensure that the wheelchair manufacturers CE-marking will remain intact.

Manufacturers manuals for all the wheelchairs, which have been approved and CE-marked with the Dahl Docking System can be downloaded from our homepage.

WHEELCHAIR - Make & Model	Possibility of fitting the docking lock plate is standard feature on wheelchair	Retrofittable adaptation kit available from Dahl Engineering	Retrofittable adaptation kit available from Wheelchair manufacturer	Adaptation kit CANNOT be retro fitted. Adaptation kit only available from wheelchair manufacturer if ordering option with wheelchair.	Compatible with VarioDock
Alu Rehab Netti Mobile D1		#501822			✓
Baldertech Finesse			Balder#HP20071413		✓
Baldertech Junior			Balder#HP20071413		✓
Degonda T4 2x2		#503213			✓
Degonda T4 Compact		#503213			✓
Degonda T4 X-Panda		#503213			✓
Dietz Power Sango F			Dietz#5000062		✓
Dietz Power Sango M			Dietz#5000062		✓
Dietz Power Sango R			Dietz#5000062		✓
Dietz Power Sango Slimline M			Dietz#5001160		✓
Invacare AVIVA RX				Invacare #SP1653422	✓
Invacare FDX					✓
Invacare Storm4				#ATZ1450	✓
Invacare Storm4 Xplore				#ATF1450	✓
Invacare TDX SP2 (WB)				#SP1564843	✓
Invacare TDX SP2 (NB)				#SP1564807	✗
Invacare TDX SP2 MBL Tilt-Lifter (WB)				#SP1564843	✓
Invacare TDX SP2 MBL Tilt-Lifter (NB)				#SP1564807	✗
Karma Leon FWD Kameleon			Karma#19170000061		✓
Karma Leon FWD Versus			Karma#19170000061		✓
Karma EVO Altus / Lectus-LR		#503194			✓
Karma Medical Leon RWD			Karma#15120000023		✓
Karma Medical Morgan			Karma#4020169		✓
Karma Mid Lectus		#503339			✓
LEVO LCM 2		#502322			✓
Magic Mobility 360		#501798			✓
Medema MC 1122	✓				✓
Medema MC 1124		#502378			✗
Medema MC 1144		#503236			✓
Meyra i-Chair Mc3			Meyra#1079817		✓
Meyra 1.618 iChair Orbit		#503657			✓
Meyra 1.650 iChair Meylife		#503657			✓
Neatech EVO 1		#503340			✓
Neatech EVO 3		#502210			✓
New Live Magix			NewLive MA.O.P01. AC.Z.800003		✓
NHD LS 300		#503341			✓
Otto Bock Juvo B4 RWD		#503184			✓

Adaptation kits for the wheelchair¹

WHEELCHAIR - Make & Model	Possibility of fitting the docking lock plate is standard feature on wheelchair	Retrofittable adaptation kit available from Dahl Engineering	Retrofittable adaptation kit available from Wheelchair manufacturer	Adaptation kit CANNOT be retro fitted. Adaptation kit only available from wheelchair manufacturer if ordering option with wheelchair.	Compatible with VarioDock
Otto Bock Juvo B5/B6 FWD		#503261			✓
Otto Bock Juvo B5/B6 MWD		#503261			✓
Otto Bock Juvo B5/B6 RWD		#503261			✓
Paravan Heavy Duty			Paravan#33187		✓
Paravan PR 25		#502064			✓
Paravan PR 40		#502064			✓
Paravan PR 50			Paravan#33187		✓
Paravan Piccolino			Paravan#33187		✓
Permobil C400		#502215			✓
Permobil F3 Corpus	✓*				✓
Permobil F5 Corpus	✓*				✓
Permobil F5 Corpus VS	✓*				✓
Permobil M3 Corpus	✓*				✓
Permobil M5 Corpus	✓*				✓
Qimova PE		#502185			✓
Roltec Boa 2		#503342			✓
Quantum Rehab (Pride Mobility), Q6 Edge 2.0**		#502378			✓
Quantum Rehab (Pride Mobility), Q6 Edge 3.0**		#502378			✓
Roltec Moveo		#501819			✓
Roltec Viper			Roltec#70658		✓
Roltec CT4 RWD / Vision			Roltec#70658		✓
Scout Mobility X10 FWD		#503366			✓
Scout Mobility X10 MWD		#503366			✓
Scout Mobility X10 RWD		#503366			✓
SKS Swiss Viva Grand			SKS#22.0218		✓
SKS Swiss Viva Grand M		#503342			✓
Sunrise Medical Q100 R		#503259			✓
Sunrise Medical Q200 R		#503259			✓
Sunrise Medical Q400 F		#501798			✓
Sunrise Medical Q400 M		#501798			✓
Sunrise Medical Q500 F		#501798			✓
Sunrise Medical Q500 H		#501798			✓
Sunrise Medical Q500 M		#501798			✓
Sunrise Medical Q500 R		#501798			✓
Sunrise Medical Q700 M		#503683			✓
Sunrise Medical Q700 R		#501798			✓
Sunrise Medical QUICKIE Salsa M2 & Salsa Mini 2		#501798			✗
Sunrise Medical QUICKIE Salsa R2		#501756			✓
TA Service IQ RWD			TA #97189		✓
TA Service IQ FWD			TA #97189		✓
TA Service IQ MWD			TA #97189		✓
TA Service Indoor Wave			TA #95255		✓
Vela Blues 300			Vela #926425		✓
Wolturnus A-Run				Wolturnus #20778	✓
Wolturnus Rex 350				Wolturnus #20779	✓
Wolturnus W5				Wolturnus #20776 or 20777	✓

* Prepared for Dahl Docking is available as standard feature, however please inquire with Permobil regarding the availability in your country.

** Please inquire with the Pride/Quantum sales organization in your country regarding availability.

Adaptation kits for the wheelchair¹

WHEELCHAIRS OUT OF PRODUCTION - Make & Model	Possibility of fitting the docking lock plate is standard feature on wheelchair	Retrofittable adaptation kit available from Dahl Engineering	Retrofittable adaptation kit available from Wheelchair manufacturer	Adaptation kit CANNOT be retro fitted. Adaptation kit only available from wheelchair manufacturer if ordering option with wheelchair.
ETAC Balder Move FWD				
ETAC Balder Move RWD				
Handicare Eligo 2				
Handicare Zenith 4000R				
Huka Skwirrel 2				
Huka Skwirrel 2 - Simba seat				
Invacare Typhoon 2		#501798		
Medema Minicrosser 1103 Jazzy				
Medema MC 1170 2				
Medema 1121 Jazzy	✓			
Meyra i-Chair Mc3		#503213	Meyra#1079817	
Roltec Boa		#502046		
Sunrise Medical QUICKIE Jive F		#501578		
Sunrise Medical QUICKIE Jive M		#501570		
Sunrise Medical QUICKIE Jive R		#501578		
Sunrise Medical QUICKIE Jive R2		#501756		
Sunrise Medical QUICKIE Puma 40 FWD - SedeoPro + seating system				
Sunrise Medical QUICKIE Puma 40 RWD - SedeoPro + seating system				
Sunrise Medical QUICKIE Salsa M		#500790		
Sunrise Medical QUICKIE Salsa R		#500769		
Sunrise Medical You-Q Luca FWD Qlass seat package				
Sunrise Medical You-Q Luca RWD				
Sunrise Medical You-Q Samm MWD				
Vela Blues 1100 FWD				
Vela Blues 1100 RWD				
Wolturnus Rex				

1. Subject to wheelchair manufacturer changing specifications / This list is constantly being updated.

Wheelchairs tested with the Dahl Docking Station

We have currently tested our docking station with the following wheelchairs in accordance with ISO 10542-1:2012 and ISO 7176-19:2008. Dahl VarioDock™ can with few exceptions be used with all wheelchairs that are tested with Dahl Docking Station MK II.

Please go to our web page to see the test videos of the actual crash tests as well as the latest list of tested wheelchairs. If your wheelchair is missing on the list of tested models, we are happy to work with the wheelchair manufacturer to develop and test a solution.

More wheelchairs are continuously being tested. Please enquire with regard to the current range.

Wheelchairs tested with the Dahl Docking Station



Alu Rehab Netti Mobile D1



Baldertech Finesse



Baldertech Junior



Degonda T4 2x2



Dietz Power Sango F



Dietz Power Sango M



Dietz Power Sango R



Dietz Power Sango Slimline M

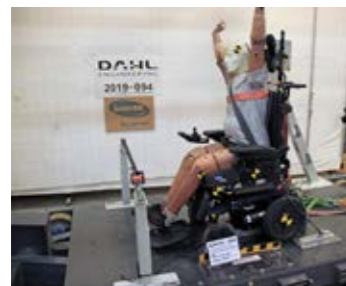

Invacare AVIVA RX



Invacare FDX



Invacare Storm4



Invacare Storm4 Xplore



Invacare TDX SP2



Invacare TDX SP2 MBL Tilt-Lifter



Karma EVO Altus / Lectus-LR



Karma Leon FWD Kameleon



Karma Leon FWD Versus



Karma Medical Leon



Karma Medical Morgan



Karma Mid Lectus



LEVO LCM 2



Magic Mobility 360



Medema MC 1122



Medema MC 1124



Medema MC 1144



Meyra iChair Mc3



Meyra 1.650 iChair Meylife



Meyra Orbit 1.618 iChair Orbit



Neatech EVO1



Neatech EVO3



New Live Magix



NHD LS 300

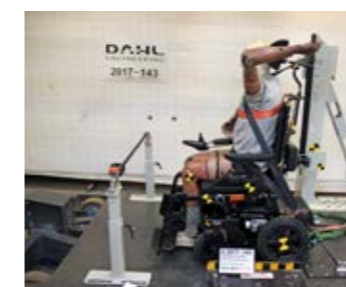

Otto Bock Juvo B4 RWD

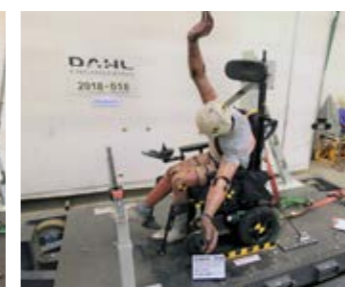

Otto Bock Juvo B4 RWD



Otto Bock Juvo B5/B6 FWD



Otto Bock Juvo B5/B6 MWD

Wheelchairs tested with the Dahl Docking Station



Otto Bock Juvo B5/B6 RWD



Otto Bock Juvo B5/B6 RWD



Paravan Heavy Duty



Paravan PR 25



Paravan PR 40



Paravan PR 50



Permobil C400



Permobil F3 Corpus



Permobil F5 Corpus



Permobil F5 Corpus VS



Permobil M3 Corpus



Permobil M5 Corpus



Quantum Rehab (Pride Mobility),
Q6 Edge 2.0

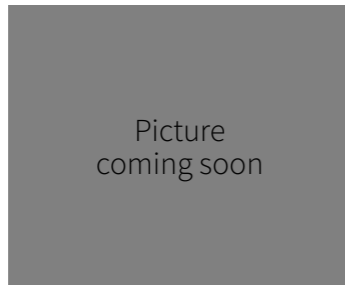

Quantum Rehab (Pride Mobility),
Q6 Edge 3.0



Qimova PE



Roltec Boa 2



Roltec Moveo



Roltec Viper



Roltec Vision



Scout Mobility X10 FWD

Wheelchairs tested with the Dahl Docking Station



Scout Mobility X10 MWD



Scout Mobility X10 RWD



SKS Swiss Viva Grand



SKS Swiss Viva Grand M



Sunrise Medical Q100 R



Sunrise Medical Q200 R



Sunrise Medical Q400 F



Sunrise Medical Q400 M



Sunrise Medical Q500 F

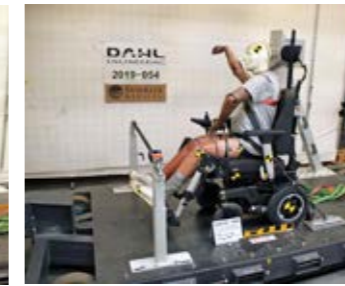

Sunrise Medical Q500 H



Sunrise Medical Q500 M



Sunrise Medical Q500 R



Sunrise Medical Q700 M



Sunrise Medical Q700 R



Sunrise Medical QUICKIE Salsa M2



Sunrise Medical QUICKIE Salsa R2



TA Service IQ RWD



TA Service IQ FWD



TA Service Indoor Wave



TA Service IQ MWD

